

Product Specification

LowPro-Series Low Profile Sewage System

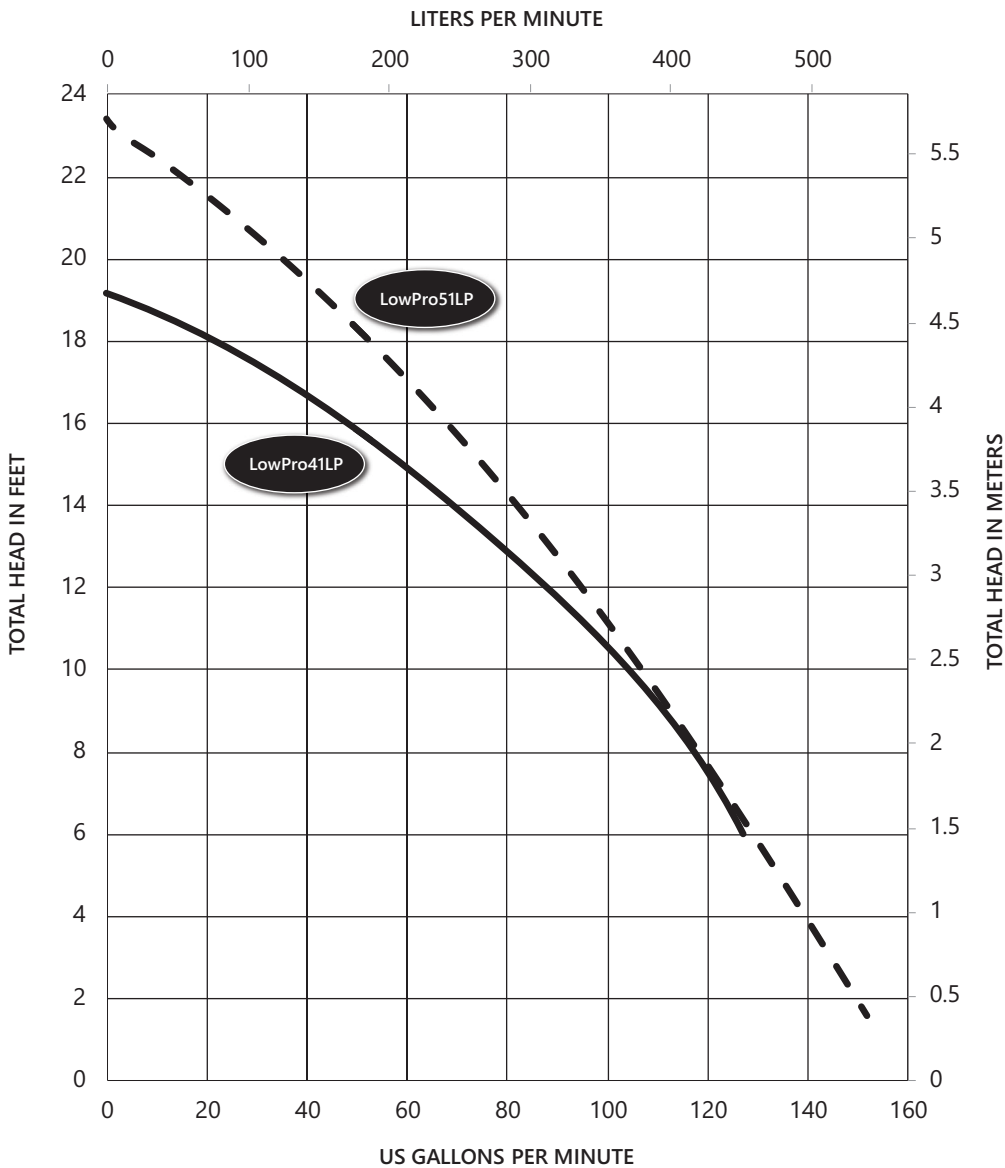
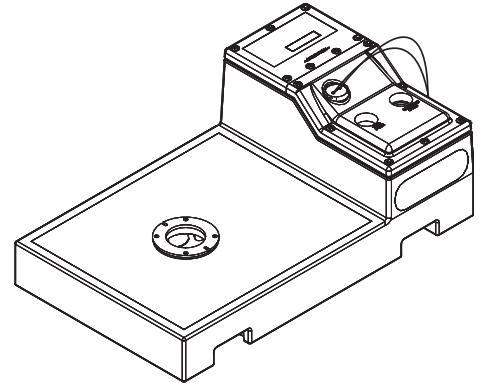

LowPro-Series Dimensional Data

TOP VIEW

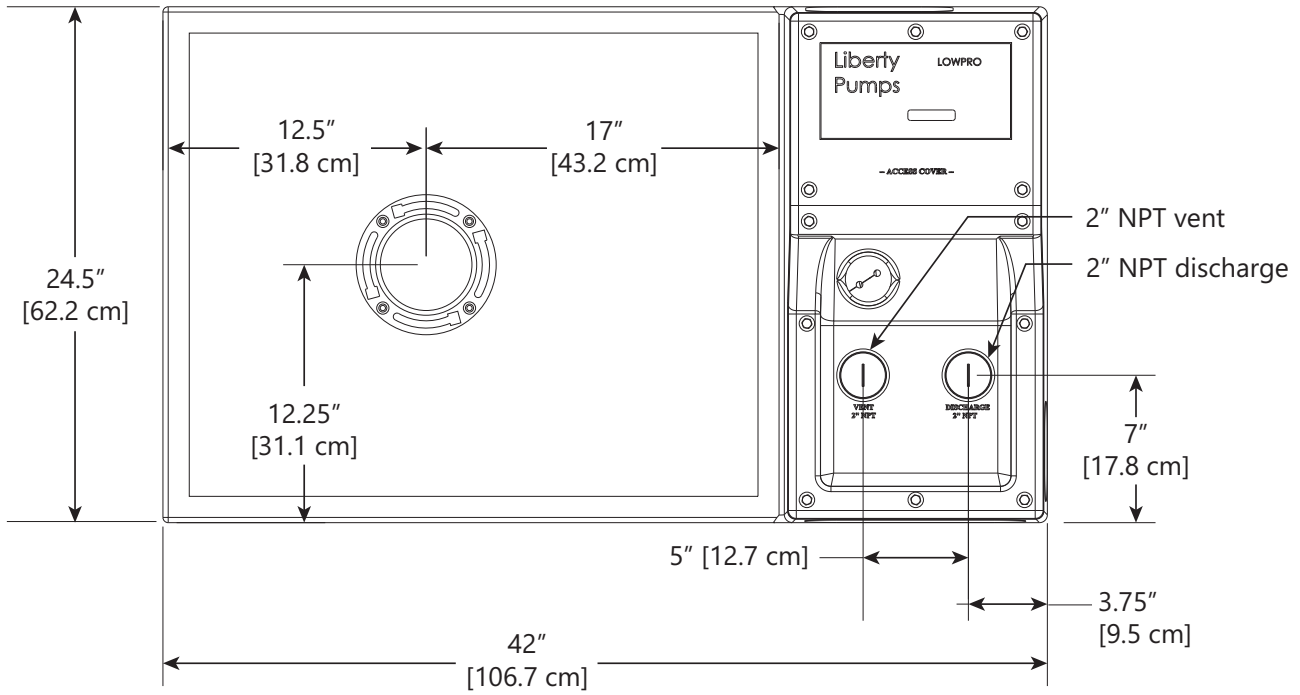

SIDE VIEW

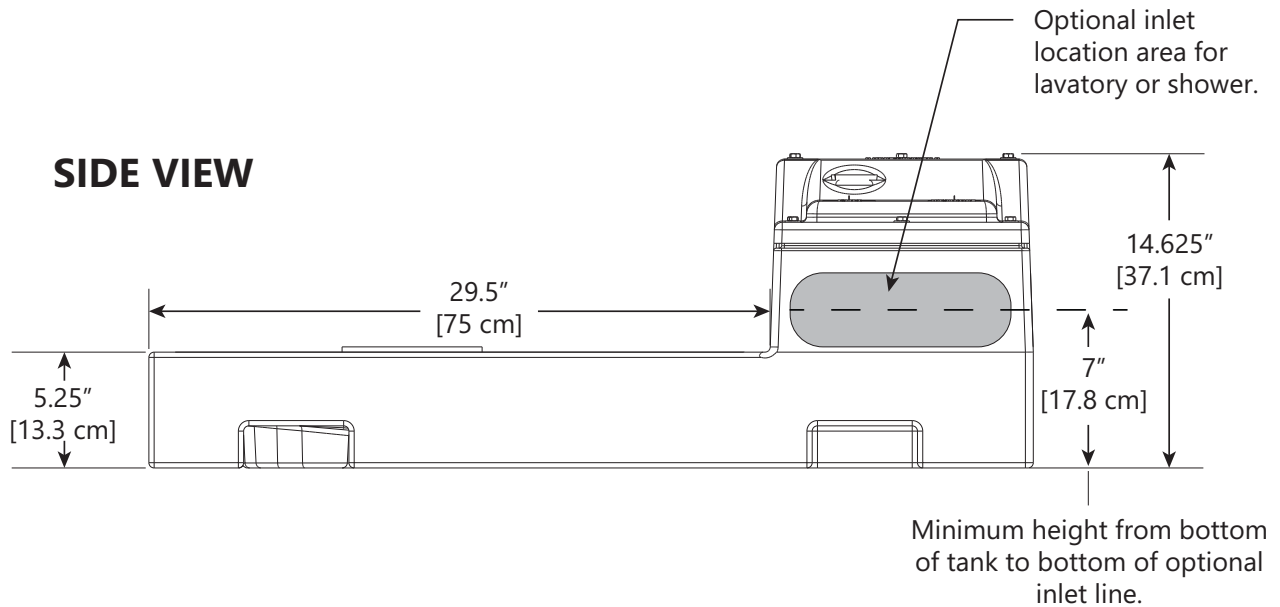

LowPro-Series Electrical Data

MODEL	HP	VOLTAGE	PHASE	FULL LOAD AMPS	LOCKED ROTOR AMPS	HZ	RPM	DISCHARGE
LowPro41LP	4/10	115	1	12	22.5	60	1725	2"
LowPro51LP	1/2	115	1	12	22.5	60	1725	2"

LowPro-Series Technical Data

ASSEMBLY			
TANK	POLYETHYLENE		
COVER	POLYPROPYLENE		
ASSEMBLED WEIGHT	41 KG / 91 LBS		
PUMP	LowPro41LP	LowPro51LP	
IMPELLER	VORTEX ENGINEERED POLYMER	2 VANE ENGINEERED THERMOPLASTIC ELASTOMER	
SOLIDS HANDLING SIZE	2"	2"	
PAINT	POWDER COAT	POWDER COAT	
MAX LIQUID TEMP	140°F	140°F	
THERMAL OVERLOAD	221°F	221°F	
MOTOR HOUSING	CLASS 25 CAST IRON	CLASS 25 CAST IRON	
VOLUTE	CLASS 25 CAST IRON	CLASS 25 CAST IRON	
SHAFT	STAINLESS	STAINLESS	
HARDWARE	STAINLESS	STAINLESS	
O-RINGS	BUNA-N	BUNA-N	
MECHANICAL SEAL	CARBON CERAMIC	CARBON CERAMIC	

LowPro41LP Specifications

1.01 GENERAL

The contractor shall provide labor, material, equipment, and incidentals required to provide _____ (QTY) centrifugal pumps as specified herein. The pump models covered in this specification are Model LE41LP single-phase pumps as manufactured by Liberty Pumps.

2.01 OPERATING CONDITIONS

Each submersible pump shall be rated at 4/10 hp, 115 Volts, single-phase, 60 Hz, 1725 RPM. The submersible pump shall be capable of handling residential sewage with 2" solids handling capability. The unit shall have a shut-off head of 19 feet and a maximum flow of 125 GPM at 6 feet of total dynamic head.

3.01 CONSTRUCTION

Each centrifugal pump shall be equal to the  Certified Model LE41LP pumps as manufactured by Liberty Pumps, Bergen NY. The castings shall be constructed of class 25 cast iron. The motor housing shall be oil-filled to dissipate heat. Air-filled motors shall not be considered equal since they do not properly dissipate heat from the motor. All mating parts shall be machined and sealed with a Buna-N O-ring. All fasteners exposed to the liquid shall be stainless steel. The motor shall be protected on the top side with a sealed cord entry plate with molded pins to conduct electricity, eliminating the ability of water to enter internally through the cord. The motor shall be protected on the lower side with a unitized ceramic carbon seal with stainless steel housings and spring.

4.01 ELECTRICAL POWER CORD

The submersible pump shall be supplied with a multi-conductor power cord. It shall be cord type SJTW, capable of continued exposure to the pumped liquid. The power cord shall be sized for the rated full load amps of the pump in accordance with the National Electric Code. The power cord shall not enter the motor housing directly but will conduct electricity to the motor by means of a watertight compression fitting cord plate assembly with molded pins to conduct electricity. This will eliminate the ability of water to enter internally through the cord via a damaged or wicking cord.

5.01 MOTORS

Single-phase motors shall be oil-filled, permanent split capacitor, class B insulated NEMA B design, rated for continuous duty. At maximum load, the winding temperature shall not exceed 266°F unsubmerged. Since air-filled motors are not capable of dissipating heat, they shall not be considered equal. The pump motor shall have an integral thermal overload switch in the windings for protecting the motor. The capacitor circuit shall be mounted internally in the pump.

6.01 BEARINGS AND SHAFT

An upper and lower ball bearing shall be required. Both bearings shall be permanently lubricated by the oil that fills the motor housing. The motor shaft shall be made of 300 or 400 series stainless steel and have a minimum diameter of 0.500".

7.01 SEALS

The pump shall have a carbon ceramic seal with stainless steel housings and spring equal to Crane Type 6A. The motor plate/housing interface shall be sealed with a Buna-N O-ring.

8.01 IMPELLER

The vortex impeller shall be constructed of engineered polymer with pump out vanes on the back shroud to keep debris away from the seal area and shall be threaded onto the motor shaft utilizing an integrally molded brass insert.

9.01 CONTROLS

All units are supplied with CSA and UL approved float switches.

10.01 PAINT

The exterior of the pump casting shall be protected with powder coat paint.

11.01 SUPPORT

The pump shall have cast iron support legs, enabling it to be a freestanding unit. The legs will be high enough to allow 2" solids to enter the volute.

12.01 SERVICEABILITY

Components required for the repair of the pump shall be shipped within a period of 24 hours.

13.01 TESTING

The pump shall have a ground continuity check and the motor chamber shall be hi-potted to test for electrical integrity, moisture content and insulation defects. The motor and volute housing shall be pressurized and an air leak decay test performed to ensure integrity of the motor housing. The pump shall be monitored for run voltage and current, and checked for noise or other malfunction.

14.01 QUALITY CONTROL

The pump shall be manufactured in an ISO 9001 certified facility.

15.01 WARRANTY

Standard limited warranty shall be 3 years.

LowPro51LP Specifications

1.01 GENERAL

The contractor shall provide labor, material, equipment, and incidentals required to provide _____ (QTY) centrifugal pumps as specified herein. The pump models covered in this specification are Model LE51LP single-phase pumps as manufactured by Liberty Pumps.

2.01 OPERATING CONDITIONS

Each submersible pump shall be rated at 1/2 hp, 115 Volts, single-phase, 60 Hz, 1725 RPM. The submersible pump shall be capable of handling residential sewage with 2" solid handling capability. The unit shall have a shut-off head of 23 feet and a maximum flow of 152 GPM at 1.5 feet of total dynamic head.

3.01 CONSTRUCTION

Each centrifugal pump shall be equal to the  certified Model LE51LP pumps as manufactured by Liberty Pumps, Bergen NY. The castings shall be constructed of class 25 cast iron. The motor housing shall be oil-filled to dissipate heat. Air-filled motors shall not be considered equal since they do not properly dissipate heat from the motor. All mating parts shall be machined and sealed with a Buna-N O-ring. All fasteners exposed to the liquid shall be stainless steel. The motor shall be protected on the top side with sealed cord entry plate with molded pins to conduct electricity, eliminating the ability of water to enter internally through the cord. The motor shall be protected on the lower side with a unitized ceramic carbon seal with stainless steel housings and spring.

4.01 ELECTRICAL POWER CORD

The submersible pump shall be supplied with a multi-conductor power cord. It shall be cord type SJTW, capable of continued exposure to the pumped liquid. The power cord shall be sized for the rated full load amps of the pump in accordance with the National Electric Code. The power cord shall not enter the motor housing directly but will conduct electricity to the motor by means of a watertight compression fitting cord plate assembly, with molded pins to conduct electricity. This will eliminate the ability of water to enter internally through the cord via a damaged or wicking cord.

5.01 MOTORS

Single-phase motors shall be oil-filled, permanent split capacitor, class B insulated NEMA B design, rated for continuous duty. At maximum load, the winding temperature shall not exceed 266°F unsubmerged. Since air-filled motors are not capable of dissipating heat, they shall not be considered equal. The pump motor shall have an integral thermal overload switch in the windings for protecting the motor. The capacitor circuit shall be mounted internally in the pump.

6.01 BEARINGS AND SHAFT

An upper and lower ball bearing shall be required. Both bearings shall be permanently lubricated by the oil that fills the motor housing. The motor shaft shall be made of 300 or 400 series stainless steel and have a minimum diameter of 0.50".

7.01 SEALS

The pump shall have a unitized carbon/ceramic seal with stainless steel housings and spring equal to Crane Type 6A. The motor plate/housing interface shall be sealed with a Buna-N O-ring.

8.01 IMPELLER

The impeller shall be engineered thermoplastic elastomer, with pump out vanes on the back shroud to keep debris away from the seal area and shall be threaded to the motor shaft.

9.01 CONTROLS

All units are supplied with CSA and UL approved float switches.

10.01 PAINT

The exterior of the casting shall be protected with powder coat paint.

11.01 SUPPORT

The pump shall have cast iron support legs, enabling it to be a freestanding unit. The legs will be high enough to allow 2" solids to enter the volute.

12.01 SERVICEABILITY

Components required for the repair of the pump shall be shipped within a period of 24 hours.

13.01 TESTING

The pump shall have a ground continuity check and the motor chamber shall be hi-potted to test for electrical integrity, moisture content, and insulation defects. The motor and volute housing shall be pressurized and an air leak decay test performed to ensure integrity of the motor housing. The pump shall be monitored for run voltage and current, and checked for noise or other malfunction.

14.01 QUALITY CONTROL

The pump shall be manufactured in an ISO 9001 certified facility.

15.01 WARRANTY

Standard limited warranty shall be 3 years.